

# Каталог продукции для дома WOOD-STONE

По вопросам продаж и поддержки обращайтесь:

Алматы (727)345-47-04  
Ангарск (3955)60-70-56  
Архангельск (8182)63-90-72  
Астрахань (8512)99-46-04  
Барнаул (3852)73-04-60  
Белгород (4722)40-23-64  
Благовещенск (4162)22-76-07  
Брянск (4832)59-03-52  
Владивосток (423)249-28-31  
Владикавказ (8672)28-90-48  
Владимир (4922)49-43-18  
Волгоград (844)278-03-48  
Вологда (8172)26-41-59  
Воронеж (473)204-51-73  
Екатеринбург (343)384-55-89

Иваново (4932)77-34-06  
Ижевск (3412)26-03-58  
Иркутск (395)279-98-46  
Казань (843)206-01-48  
Калининград (4012)72-03-81  
Калуга (4842)92-23-67  
Кемерово (3842)65-04-62  
Киров (8332)68-02-04  
Коломна (4966)23-41-49  
Кострома (4942)77-07-48  
Краснодар (861)203-40-90  
Красноярск (391)204-63-61  
Курск (4712)77-13-04  
Курган (3522)50-90-47  
Липецк (4742)52-20-81

Магнитогорск (3519)55-03-13  
Москва (495)268-04-70  
Мурманск (8152)59-64-93  
Набережные Челны (8552)20-53-41  
Нижний Новгород (831)429-08-12  
Новокузнецк (3843)20-46-81  
Ноябрьск (3496)41-32-12  
Новосибирск (383)227-86-73  
Омск (3812)21-46-40  
Орел (4862)44-53-42  
Оренбург (3532)37-68-04  
Пенза (8412)22-31-16  
Петрозаводск (8142)55-98-37  
Псков (8112)59-10-37  
Пермь (342)205-81-47

Ростов-на-Дону (863)308-18-15  
Рязань (4912)46-61-64  
Самара (846)206-03-16  
Санкт-Петербург (812)309-46-40  
Саратов (845)249-38-78  
Севастополь (8692)22-31-93  
Саранск (8342)22-96-24  
Симферополь (3652)67-13-56  
Смоленск (4812)29-41-54  
Сочи (862)225-72-31  
Ставрополь (8652)20-65-13  
Сургут (3462)77-98-35  
Сыктывкар (8212)25-95-17  
Тамбов (4752)50-40-97  
Тверь (4822)63-31-35

Тольятти (8482)63-91-07  
Томск (3822)98-41-53  
Тула (4872)33-79-87  
Тюмень (3452)66-21-18  
Ульяновск (8422)24-23-59  
Улан-Удэ (3012)59-97-51  
Уфа (347)229-48-12  
Хабаровск (4212)92-98-04  
Чебоксары (8352)28-53-07  
Челябинск (351)202-03-61  
Череповец (8202)49-02-64  
Чита (3022)38-34-83  
Якутск (4112)23-90-97  
Ярославль (4852)69-52-93

Россия +7(495)268-04-70

Казахстан +7(727)345-47-04

Беларусь +(375)257-127-884

Узбекистан +998(71)205-18-59

Киргизия +996(312)96-26-47

эл.почта: [wes@nt-rt.ru](mailto:wes@nt-rt.ru) || сайт: <https://wood-stone.nt-rt.ru/>



# contents

**the same oven** used by famous chefs and restaurants | 5

**amazing food** more than a pizza oven | 7

**hearthside** indoors or outdoors | 8

**fuel your passion** gas-fired, wood-fired or combination of both | 9

**oven overview** bistro home and mountain home | 10

**why wood stone?** cook like the professionals | 12

**5-step quick start guide** not sure where to start? | 14

**bistro home ovens** | 16

**bistro home specifications** | 18

bistro home 3030 | 19

bistro home 4836 | 21

bistro home 4343 | 23

bistro home 4355 | 25

**bistro home configuration options** | 27

**mountain home ovens** | 28

**mountain home specifications** | 30

mt. chuckanut 4' | 31

mt. adams 5' | 33

**mountain home configuration options** | 35

mh facade extension dimensions | 36

mh mantle dimensions | 37

stone hearth oven tools | 38

tool hanger | 39

variable speed exhaust fan | 40

optional oven doors | 41

storage boxes | 42

ash dolly & wood cart | 43

ceramic log sets | 44

**professional series grill** | 46

**photo gallery** | 50

**made in the usa** from our home to your home | 58

**history** | 60

**resources** | 61

**warranty** | 62

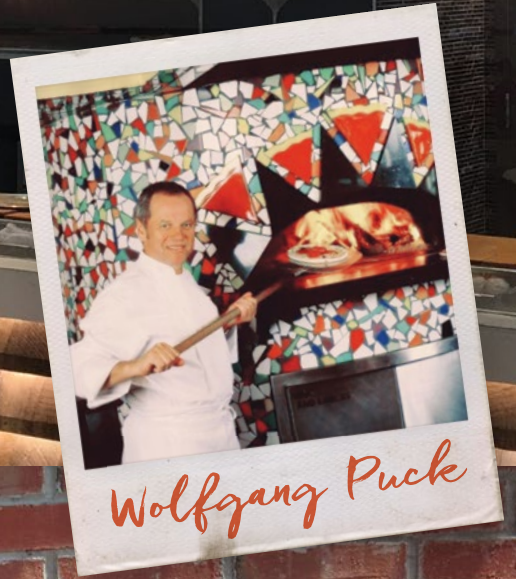

# the same oven

*used by famous chefs and restaurants*

**Cook like the pros. With a Wood Stone Home oven, you can cook with the same oven favored by world-famous chefs such as Wolfgang Puck and Bobby Flay.**

Our ovens are a true extension of our commercial line – not a scaled down version.

They are built from the ground up with the perfect blend of high tech, high touch and innovation that our loyal customers have come to expect. Why should homeowners settle for anything less than the best...perfection?





# amazing food

*more than a pizza oven*

**Discover the magic of roasting succulent poultry, baking a light and airy frittata, searing a rib-eye steak with a flambéed pan sauce and doing a lightning quick sauté of vegetables.** Use the residual heat held in the oven after it's turned off to slowly braise lamb shanks and pork shoulders to delicious, tender perfection. Cook food from all sides at consistently high temperatures — locking in moisture and creating colorful and unique flavors that are proven to set your food experience apart.





# hearthside

*indoors or outdoors*





fuel your passion

*gas-fired, wood-fired or combination of both*



# oven overview

## *Bistro Home*

**Space limitations?** Bistro Home ovens can be disassembled to fit through any standard door opening (32") and, with their compact footprint, are installed easily into any kitchen. With their stainless steel exterior, they can be set in place with no facade necessary.

Bistro Home ovens come with a wide range of accessories and tools to make your installation and design attractive and functional, while fitting your lifestyle and aesthetic needs.

*\*The Bistro Home 3030 and 4836 are available in gas-fired only.*



**bistro home 3030\***



**bistro home 4836\***



**bistro home 4343**

## *Mountain Home*

**Inspired by traditional Italian oven shapes,** the Mountain Home oven is the natural centerpiece for any kitchen. Mountain Home ovens offer large cooking surfaces and provide a variety of facade options.

Let us help you design the oven that works for you, whether by choosing facade extensions or custom finishes.



**bistro home 4355**



**mt. chuckanut 4'**



**mt. adams 5'**

# why wood stone?

*Commercial-grade equipment for the homeowner*

**We retain our high standards of quality for the residential market.**

## **cook like the professionals**

Wood Stone Home ovens incorporate all of the same quality features as those available in Wood Stone's commercial stone hearth oven line. The one distinction: a listing for residential use.

## **our reputation**

Wood Stone has been proudly manufacturing stone hearth ovens in Bellingham, WA USA for the commercial market since 1990. With thousands of installations worldwide, look for Wood Stone ovens at California Pizza Kitchen, Wolfgang Puck, Blaze Pizza, Whole Foods Market, and other commercial foodservice operations near you.

## **customer service**

At Wood Stone, we provide unparalleled service – call and talk to a real person! With Wood Stone you get lifetime support, a complimentary cooking class with Wood Stone Home corporate chefs, instructional recipe videos, our blog and additional social media channels.

## **cooking**

There is no other product on the market that can achieve the consistent cooking results of a Wood Stone oven. The intense heat is distributed in three forms:

**Natural convection** because of the designed shape of the oven.

**Radiant heat** from the golden flame in the rear, optimized for hearth cooking.

**Conductive energy** from the floor which utilizes a proprietary ceramic material developed specifically for hearth cooking.

When all three of these styles of heat work together, juices are locked into the food all while creating natural caramelization which brings out the most flavor possible. The result: your food tastes better when cooked in a Wood Stone Home oven.

## *how we're different*

- **Proprietary Materials**

Wood Stone produces highly engineered equipment combined with patented materials and processes to provide premier quality stone hearth cooking equipment.

- **Single Piece Floor and Dome Construction**

Wood Stone Home ovens, like our commercial stone hearth ovens, are made with a single piece floor and dome. Monolithic piece construction means more even and consistent cooking.

- **Thickness**

Wood Stone Bistro Home ovens have a 3-inch thick floor and dome and our Mountain Home ovens (larger models) have a 4-inch thick floor and dome. The thickness of our materials allows for more thermal mass to be created and stored, requiring less fuel.

- **Dome Height**

Wood Stone Home ovens have a high dome ceiling that creates more thermal head space and therefore requires less fuel.

- **Superior Insulating Materials**

Because of Wood Stone's proprietary materials, we are able to minimize the thickness of our insulation, creating a larger cooking surface in a footprint equivalent to other industry options.

- **Quick Heat-Up Time**

Wood Stone is the only stone hearth oven manufacturer to offer a heat-efficiency door. Place this accessory into the doorway of the oven, and decrease your heat-up time while saving energy.

- **Ease of Installation**

Wood Stone Home ovens arrive fully assembled. You can also order your oven "facade-ready" to easily accommodate the addition of finish materials when your oven arrives.

Because of the design simplicity and quality of our components, our ovens provide the most predictable cooking environment in the hearth oven category. Ease of use means better cooking results and an enjoyable cooking experience for both novice and seasoned cooks

- **Ease of Use**

In addition to wood-fired ovens, Wood Stone offers the convenience of a gas-fired fuel option (natural gas and liquid propane). Want to cook with both? No problem, most of our models can accommodate both gas-fired and wood-fired cooking.

- **Custom Finish Options**

A variety of custom finish options are available to help you achieve your design goals.

- **Temperature Reading**

Wood Stone Home ovens measure temperature from within the floor (not in the dome). This gives you the most accurate reading of the cooking surface, allowing for greater control and precision.

- **Listed and Approved for Home Use**

Built to Wood Stone's high standards of safety and performance from the ground up for use indoors or outdoors.

- **Construction**

All of our ovens are built and tested in our factory in Bellingham, WA (Made in the USA), and sent to the client fully assembled, so there is no need to rely on a mason to build the oven (and cross your fingers that he/she has done it properly). Our Wood Stone Home ovens are built identically to our commercial models, but with a residential listing.

- **Versatility**

The variety of foods you can cook is incredible. This is not just a pizza oven. You can bake, roast, sauté, braise, broil, fry, sear, caramelize, flambé, steam, poach, and soufflé. There is not a more versatile cooking appliance available.

# 5-step

## quick start guide

### Not sure where to start when considering a Wood Stone Home oven?

The process will be much smoother if you take the time to think through the entire installation scenario. You can eliminate challenges by scouting out your path to installation before the oven arrives. Remember, a Wood Stone Home oven is a large and heavy piece of equipment that requires a different level of forethought than a standard appliance. Let us help you get started.



#### 1 *indoors or outdoors?*

Wood Stone Home ovens are engineered and designed to be installed indoors or outdoors. Some locations lend themselves more easily to a smooth set-up than others. Please consider all installation details below when choosing your oven's location.

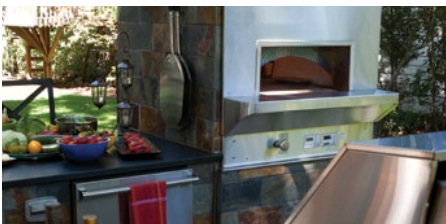

#### 2 *installation prep*

- How much space do you have for an oven?
- Plan for oven weight and required clearances.
- How do you plan to receive the oven (shipping arrangements)?
- Is the path to the installation easy to navigate?
- Research your ventilation requirements.
- Do you have access to the required utilities?



#### 3 *fuel choices*

What fuel source would you like to use for your Wood Stone Home oven? (The Bistro Home 3030 and 4836 are available in gas-fired only). Not sure what fuel source to select? Order your oven configured for gas/wood combo.

Gas versus wood. What's the better choice? Our answer is always that the fuel source is not the secret of the oven; the stone hearth is the secret.

**Gas:** While wood was the norm, Wood Stone responded to the needs of its customers with a modern spin on the Old World cooking style by introducing gas (either natural gas or propane) to the mix. Gas provides the same high heat AND the same great flavor profiles, but with the convenience and control that are not available with wood-only ovens.

**Wood:** The use of wood as a fuel source goes back to the roots of stone hearth cooking and was the standard heat source for thousands of years. Wood Stone was founded using wood-only designs and we have over 25+ years of experience in the use of wood as a heat source.

**Gas/Wood Combo:** But why not have both? If you long for the ambiance of a wood-fired oven but are looking for the convenience and control that gas offers, Wood Stone Home ovens (except the gas-only Bistro Home 3030) can be configured to burn gas, wood or a combination of both.



#### 4 facade and finish options

Wood Stone Home ovens are easy to personalize. We recommend looking at the installation examples in our online photo gallery for inspiration. Not sure how to achieve the look you want? Call us, and we can help customize your order.

#### 5 ventilation

Each Wood Stone Home oven installation is unique. Because our ovens can be installed indoors or outdoors, recommendations for ventilation vary. All indoor installations require an exhaust fan, but most outdoor installations do not. Please consult your contractor or call the factory if you have any questions.

##### outdoor installations

If your Wood Stone Home oven is being installed outdoors, **without** the protection of covering from above (i.e. roof, patio, gazebo, etc...\*\*), the flue of the oven will need to be protected from the elements with a rain cap. You can supply your own (see photo, bottom right), or Wood Stone can provide a chimney for your outdoor oven application. This accessory will need to be installed before starting your oven.

\*\*Please note, if you are installing your oven outdoors under a covered area, it may need to be vented similar to an indoor installation.



Wood Stone's **Chimneys**

Owner-provided **rain cap**



REVISED: February 2018, r01

#### Air Quality Restrictions and Wood Burning Regulations

Our wood-fired ovens and gas/wood combination ovens are usually classified as wood burning (solid fuel) cooking equipment and are often exempt from wood burning restrictions that pertain to wood stoves and other wood-fired heating appliances. If there are wood burning restrictions in your area, please check with the appropriate local and state air quality agencies to determine what, if any, restrictions may apply to solid fuel burning cooking equipment. For areas where wood burning is restricted, our gas-fired ovens are an exceptional alternative.

# bistro home ovens

Beautiful kitchens have always been major contributors to a home's livability and enjoyment, and a Wood Stone Bistro Home Oven takes that equation to a whole new level. Whether you install a Wood Stone Bistro Home Oven in your current kitchen, plan one in your next home or decide on a kitchen addition (indoors or outdoors), a Wood Stone Home oven will make your kitchen the visual and culinary showpiece of your home.





# specifications

## *bistro home*

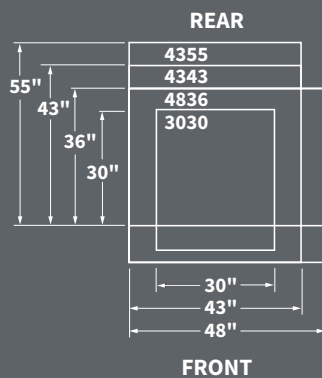

**bistro home  
footprint**

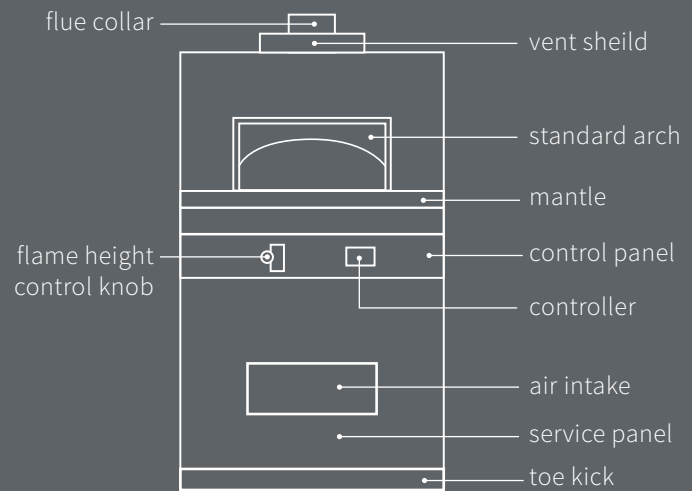

**bistro home  
front view**





**bistro home 3030**

## MODEL OPTIONS

### Gas-Fired Only

Natural Gas: WS-BH-3030-**RFG-NG**

Liquid Propane: WS-BH-3030-**RFG-LP**

*please note: gas type (NG) or (LP) must be specified at time of order*

## STONE HEARTH CAPACITY

**8" pizza: 4**

**10" pizza: 2-3**

**12" pizza: 1**

## OPTIONAL ACCESSORIES

- Stainless Steel Oven Tool Set & Tool Hanger
- Variable Speed Exhaust Fan
- Tempered Glass Doors
- Granite Mantle
- Stainless Steel Storage Box

### Air Quality Restrictions and Wood Burning Regulations.

Our wood-fired ovens and gas/wood combination ovens are usually classified as wood burning (solid fuel) cooking equipment and are often exempt from wood burning restrictions that pertain to wood stoves and other wood-fired heating appliances. If there are wood burning restrictions in your area, please check with the appropriate local and state air quality agencies to determine what, if any, restrictions may apply to solid fuel burning cooking equipment. For areas where wood burning is restricted, our gas-fired ovens are an exceptional alternative.

**job name:**

**model:**

**WS-BH-3030**

**item#:**

**fuel type:**

**Gas-Fired Only**

## FEATURES

- Standard door opening: 18.5 inches wide x 10 inches high
- Almost 3 square feet of cooking surface which allows for the preparation of an array of foods - perfect for entertaining
- Monolithic ceramic floor and monolithic dome provide greater strength and more even heat distribution (compared to tile floors and multi-piece domes)
- Ceramic interior is heated by an adjustable radiant flame burner in the back of the oven which provides a powerful and attractive yellow flame
- Appliance body and control panel are enclosed with stainless steel and the service panel and toe kick are made of stainless steel. The unit is supported by a black, heavy-duty steel stand
- Only 1-inch side and back clearance to combustible building materials required
- ETL Listed for residential indoor or outdoor installation
- Comes standard with stainless steel mantle and log set
- Made in the USA

*The oven arrives assembled and ready for installation. For ease of installation the oven can be disassembled to fit through 32-inch openings. Facade by others.*

# Bistro Home 3030



**plan view**

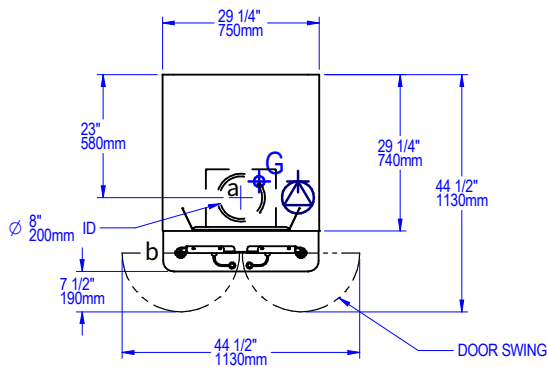

**rear view**

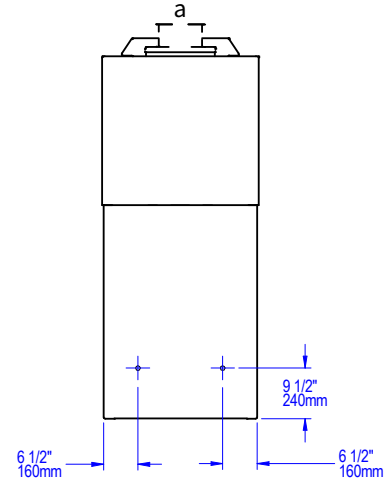

**front view**

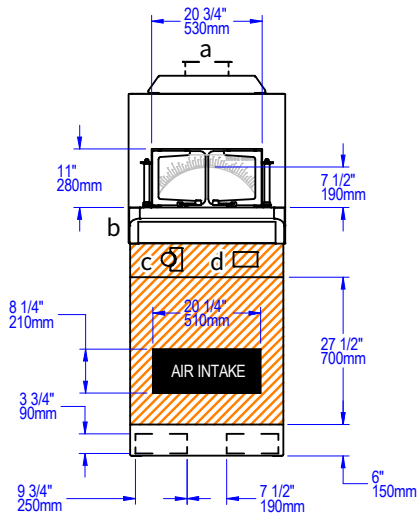

**side view**

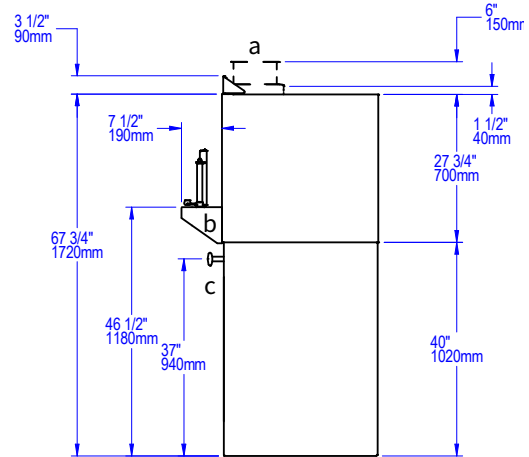

a	flue collar
b	mantle
c	flame height control knob
d	control panel
MUST BE LEFT REMOVABLE FOR SERVICE	

please note: either the air intake panel OR the perforation on the toe kick needs to be left open (do not cover/facade over) to allow for proper airflow.



## UTILITIES ⚡

Gas: 3/4 inch gas inlet (FNPT)  
55,000 BTU/hr Natural Gas (NG) Supply  
OR  
48,000 BTU/hr Propane (LP) Supply

## ELECTRICAL ⚡

120 VAC, 2 A, 60 Hz  
All utility connections made on the back of the oven control box beneath the oven. Remove front or rear panel for access, use utility knockouts (provided) to route gas and electrical supplies.

## VENTING

This BH appliance vents through an 8-inch O.D. flue collar located above the doorway. Direct connect to a Listed building heating appliance chimney, also Listed as a grease duct, or a grease duct constructed in accordance with NFPA 96 and all relevant local and national codes, and in a manner acceptable to the authority having jurisdiction. Most installations will require an exhaust fan. See the installation manual for details.



**bistro home 4836**

## MODEL OPTIONS

**Gas-Fired Only:**

Natural Gas: WS-BH-4836-**RFG-NG**

Liquid Propane: WS-BH-4836-**RFG-LP**

*please note: gas type (NG) or (LP) must be specified at time of order*

## STONE HEARTH CAPACITY

**8" pizza: 8**

**10" pizza: 6**

**12" pizza: 4**

## OPTIONAL ACCESSORIES

- Stainless Steel Oven Tool Set & Tool Hanger
- Variable Speed Exhaust Fan
- Tempered Glass Doors
- Granite Mantle
- Stainless Steel Storage Box

**Air Quality Restrictions and Wood Burning Regulations.**

Our wood-fired ovens and gas/wood combination ovens are usually classified as wood burning (solid fuel) cooking equipment and are often exempt from wood burning restrictions that pertain to wood stoves and other wood-fired heating appliances. If there are wood burning restrictions in your area, please check with the appropriate local and state air quality agencies to determine what, if any, restrictions may apply to solid fuel burning cooking equipment. For areas where wood burning is restricted, our gas-fired ovens are an exceptional alternative.

**job name:**

**model:**

	<b>WS-BH-4836</b>
--	-------------------

**item#:**

**fuel type:**

	<b>Gas-Fired Only</b>
--	-----------------------

## FEATURES

- Standard door opening: 24.5 inches wide x 9.75 inches high
- 5.8 square feet of cooking surface which allows for the preparation of an array of foods - perfect for entertaining
- Monolithic ceramic floor and monolithic dome provide greater strength and more even heat distribution (compared to tile floors and multi-piece domes)
- Ceramic interior is heated by an adjustable radiant flame burner in the back of the oven which provides a powerful and attractive yellow flame
- Appliance body and control panel are enclosed with stainless steel and the service panel and toe kick are made of stainless steel. The unit is supported by a black, heavy-duty steel stand
- Only 1-inch side and back clearance to combustible building materials required
- ETL Listed for residential indoor or outdoor installation
- Comes standard with stainless steel mantle and log set
- Made in the USA

*The oven arrives assembled and ready for installation. For ease of installation the oven can be disassembled to fit through 32-inch openings. Facade by others.*

# Bistro Home 4836



**plan view**

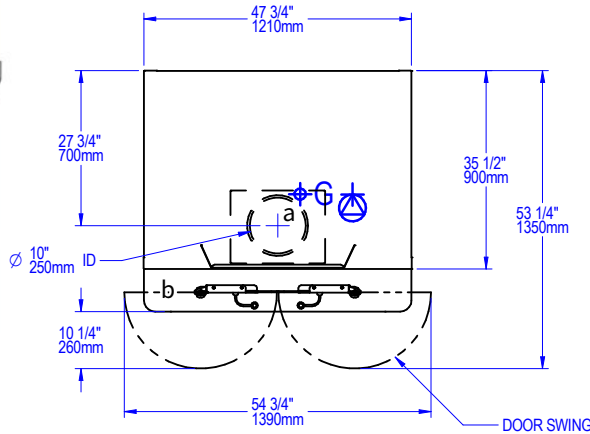

**rear view**

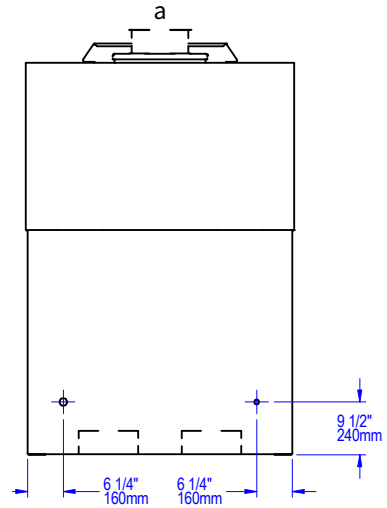

**front view**

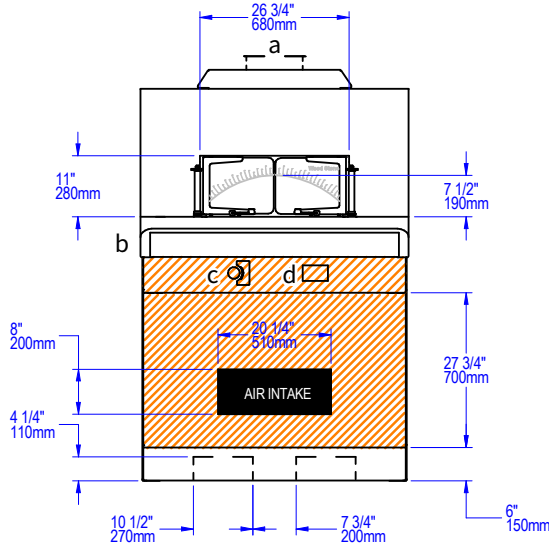

**side view**

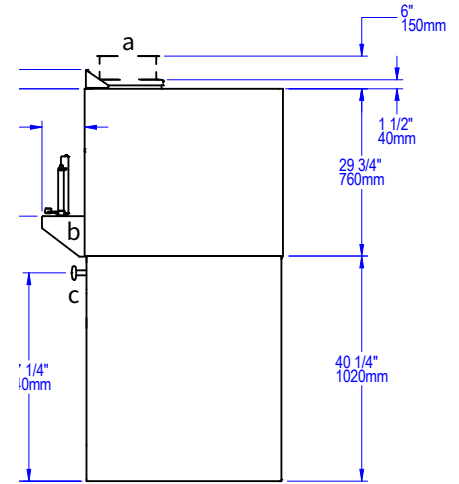

a	flue collar
b	mantle
c	flame height control knob
d	control panel
MUST BE LEFT REMOVABLE FOR SERVICE	
please note: either the air intake panel OR the perforation on the toe kick needs to be left open (do not cover/facade over) to allow for proper airflow.	



**UTILITIES** ⚡

Gas: 3/4 inch gas inlet (FNPT)  
80,500 BTU/hr Natural Gas (NG) Supply  
OR  
80,500 BTU/hr Propane (LP) Supply

**ELECTRICAL** ⚡

120 VAC, 2 A, 60 Hz  
All utility connections made on the back of the oven control box beneath the oven. Remove front or rear panel for access, use utility knockouts (provided) to route gas and electrical supplies.

**VENTING**

This BH appliance vents through an 10-inch O.D. flue collar located above the doorway. Direct connect to a Listed building heating appliance chimney, also Listed as a grease duct, or a grease duct constructed in accordance with NFPA 96 and all relevant local and national codes, and in a manner acceptable to the authority having jurisdiction. Most installations will require an exhaust fan. See the installation manual for details.



**bistro home 4343**

## MODEL OPTIONS

### Gas-Fired Only:

Natural Gas: WS-BH-4343-**RFG-NG**

Liquid Propane: WS-BH-4343-**RFG-LP**

*please note: gas type (NG) or (LP) must be specified at time of order*

**Wood-Fired Only:** WS-BH-4343-**W**

**Combination:** WS-BH-4343-**RFG-W-(NG or LP)**

## STONE HEARTH CAPACITY

**8" pizza: 8**

**10" pizza: 6**

**12" pizza: 3-4**

## OPTIONAL ACCESSORIES

- Stainless Steel Oven Tool Set & Tool Hanger
- Variable Speed Exhaust Fan
- Tempered Glass Doors
- Granite Mantle
- Stainless Steel Storage Box
- Wood Burning Option

### Air Quality Restrictions and Wood Burning Regulations.

Our wood-fired ovens and gas/wood combination ovens are usually classified as wood burning (solid fuel) cooking equipment and are often exempt from wood burning restrictions that pertain to wood stoves and other wood-fired heating appliances. If there are wood burning restrictions in your area, please check with the appropriate local and state air quality agencies to determine what, if any, restrictions may apply to solid fuel burning cooking equipment. For areas where wood burning is restricted, our gas-fired ovens are an exceptional alternative.

**job name:**

**model:**

**WS-BH-4343**

**item#:**

**fuel type:**

**Gas-Fired, Wood-Fired or Combination**

## FEATURES

- Standard door opening: 24.5 inches wide x 9.75 inches high
- 6.4 square feet of cooking surface which allows for the preparation of an array of foods - perfect for entertaining
- Monolithic ceramic floor and monolithic dome provide greater strength and more even heat distribution (compared to tile floors and multi-piece domes)
- Ceramic interior is heated by an adjustable radiant flame burner in the back of the oven which provides a powerful and attractive yellow flame
- Appliance body and control panel are enclosed with stainless steel and the service panel and toe kick are made of stainless steel. The unit is supported by a black, heavy-duty steel stand
- Only 1-inch side and back clearance to combustible building materials required
- ETL Listed for residential indoor or outdoor installation
- Comes standard with stainless steel mantle and log set
- Made in the USA

*The oven arrives assembled and ready for installation. For ease of installation the oven can be disassembled to fit through 32-inch openings. Facade by others.*

# Bistro Home 4343



**plan view**

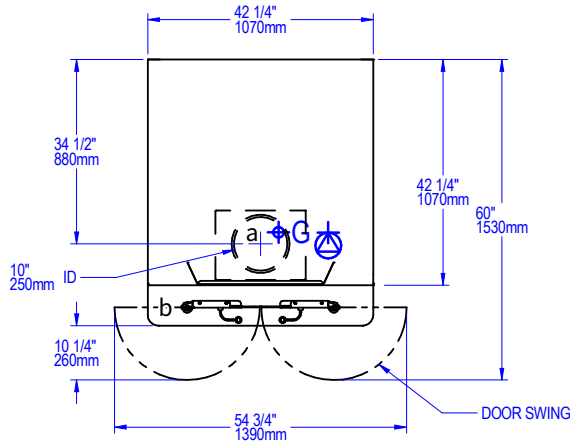

**rear view**

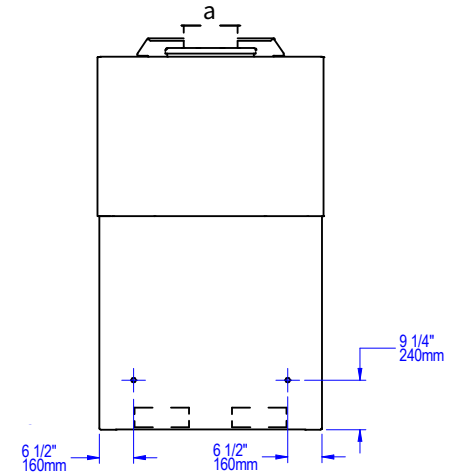

**front view**

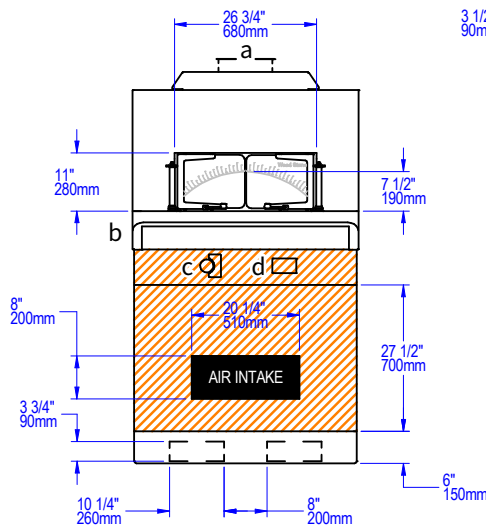

**side view**

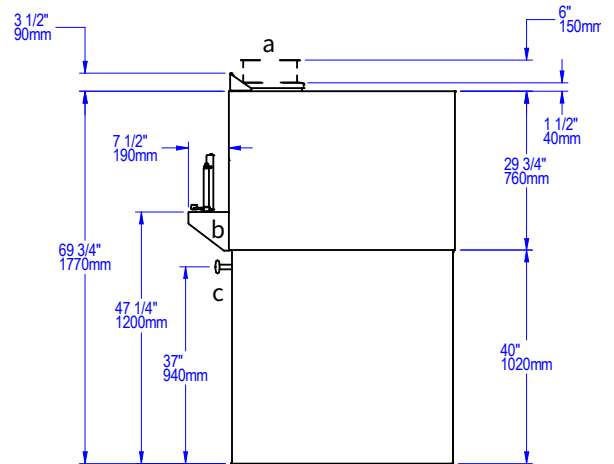

a	flue collar
b	mantle
c	flame height control knob
d	control panel
MUST BE LEFT REMOVABLE FOR SERVICE	

please note: either the air intake panel OR the perforation on the toe kick needs to be left open (do not cover/facade over) to allow for proper airflow.



**UTILITIES** ⚡

Gas: 3/4 inch gas inlet (FNPT)  
 80,500 BTU/hr Natural Gas (NG) Supply  
 OR  
 80,500 BTU/hr Propane (LP) Supply

**ELECTRICAL** ⚡

120 VAC, 2 A, 60 Hz  
 All utility connections made on the back of the oven control box beneath the oven. Remove front or rear panel for access, use utility knockouts (provided) to route gas and electrical supplies.

**VENTING**

This BH appliance vents through an 10-inch O.D. flue collar located above the doorway. Direct connect to a Listed building heating appliance chimney, also Listed as a grease duct, or a grease duct constructed in accordance with NFPA 96 and all relevant local and national codes, and in a manner acceptable to the authority having jurisdiction. Most installations will require an exhaust fan. See the installation manual for details.



## bistro home 4355

### MODEL OPTIONS

#### Gas-Fired Only:

Natural Gas: WS-BH-4355-**RFG-NG**

Liquid Propane: WS-BH-4355-**RFG-LP**

*please note: gas type (NG) or (LP) must be specified at time of order*

**Wood-Fired Only:** WS-BH-4355-**W**

**Combination:** WS-BH-4355-**RFG-W-(NG or LP)**

### STONE HEARTH CAPACITY

**8" pizza: 12**

**10" pizza: 9**

**12" pizza: 6**

**14" pizza: 4**

### OPTIONAL ACCESSORIES

- Stainless Steel Oven Tool Set & Tool Hanger
- Variable Speed Exhaust Fan
- Tempered Glass Doors
- Granite Mantle
- Stainless Steel Storage Box
- Wood Burning Option

#### Air Quality Restrictions and Wood Burning Regulations.

Our wood-fired ovens and gas/wood combination ovens are usually classified as wood burning (solid fuel) cooking equipment and are often exempt from wood burning restrictions that pertain to wood stoves and other wood-fired heating appliances. If there are wood burning restrictions in your area, please check with the appropriate local and state air quality agencies to determine what, if any, restrictions may apply to solid fuel burning cooking equipment. For areas where wood burning is restricted, our gas-fired ovens are an exceptional alternative.

**job name:**

**model:**

**WS-BH-4355**

**item#:**

**fuel type:**

**Gas-Fired, Wood-Fired or Combination**

### FEATURES

- Standard door opening: 24.5 inches wide x 9.75 inches high
- 9.2 square feet of cooking surface which allows for the preparation of an array of foods - perfect for entertaining
- Monolithic ceramic floor and monolithic dome provide greater strength and more even heat distribution (compared to tile floors and multi-piece domes)
- Ceramic interior is heated by an adjustable radiant flame burner in the back of the oven which provides a powerful and attractive yellow flame
- Appliance body and control panel are enclosed with stainless steel and the service panel and toe kick are made of stainless steel. The unit is supported by a black, heavy-duty steel stand
- Only 1-inch side and back clearance to combustible building materials required
- ETL Listed for residential indoor or outdoor installation
- Comes standard with stainless steel mantle and log set
- Made in the USA

*The oven arrives assembled and ready for installation. For ease of installation the oven can be disassembled to fit through 32-inch openings. Facade by others.*

# Bistro Home 4355



**plan view**

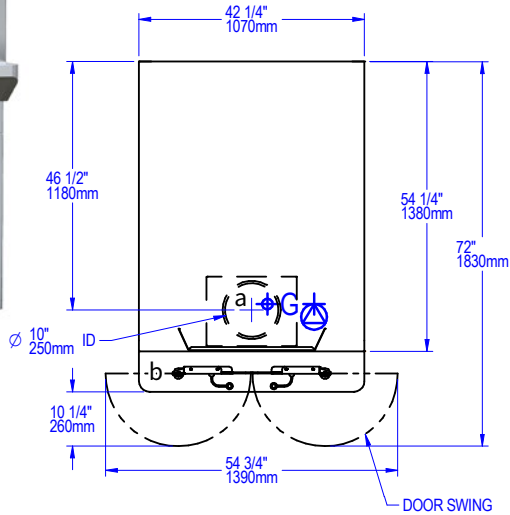

**rear view**

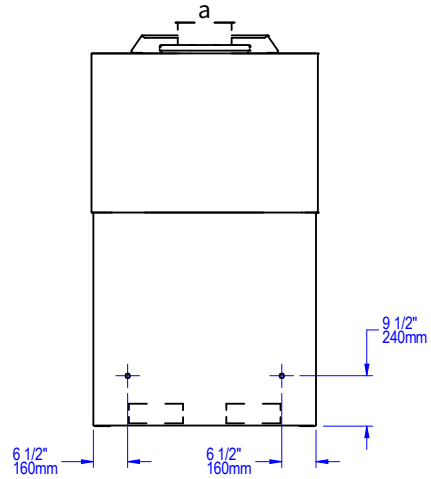

**front view**

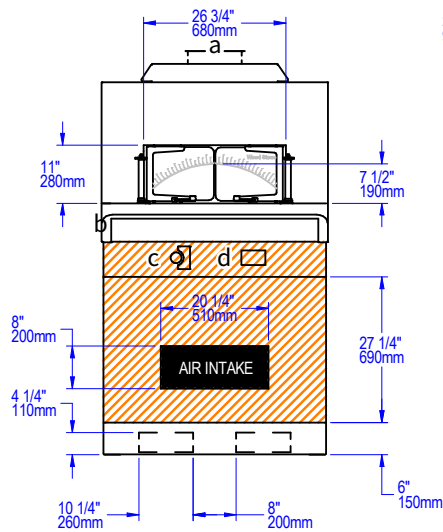

**side view**

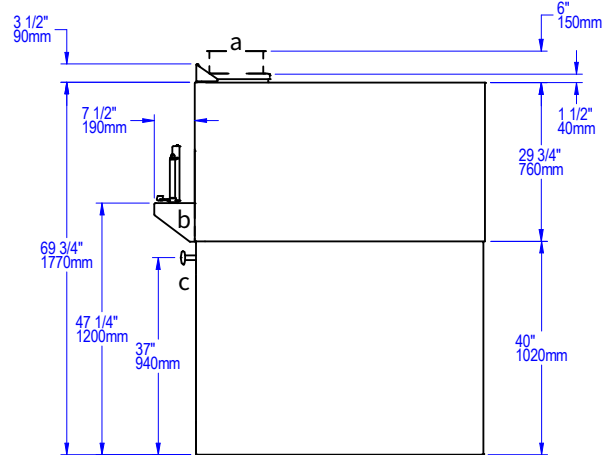

a	flue collar
b	mantle
c	flame height control knob
d	control panel
MUST BE LEFT REMOVABLE FOR SERVICE	

please note: either the air intake panel OR the perforation on the toe kick needs to be left open (do not cover/facade over) to allow for proper airflow.



**UTILITIES** ⚡Ⓖ

Gas: 3/4 inch gas inlet (FNPT)  
 80,500 BTU/hr Natural Gas (NG) Supply  
 OR  
 80,500 BTU/hr Propane (LP) Supply

**ELECTRICAL** ⚡

120 VAC, 2 A, 60 Hz  
 All utility connections made on the back of the oven control box beneath the oven. Remove front or rear panel for access, use utility knockouts (provided) to route gas and electrical supplies.

**VENTING**

This BH appliance vents through an 10-inch O.D. flue collar located above the doorway. Direct connect to a Listed building heating appliance chimney, also Listed as a grease duct, or a grease duct constructed in accordance with NFPA 96 and all relevant local and national codes, and in a manner acceptable to the authority having jurisdiction. Most installations will require an exhaust fan. See the installation manual for details.

## FEATURES

### bistro home configuration options

Wood Stone offers a wide range of accessories to help make your final oven installation seamless and attractive.

<b>a.</b>	curved stainless steel mantle
<b>b.</b>	curved granite-ready mantle
<b>c.</b>	curved stainless steel mantle with doors
<b>d.</b>	curved granite-ready mantle with doors
<b>e.</b>	stainless steel storage box
<b>f.</b>	stainless steel service panel

job name:

model:

--	--

item#:

fuel type:

--	--

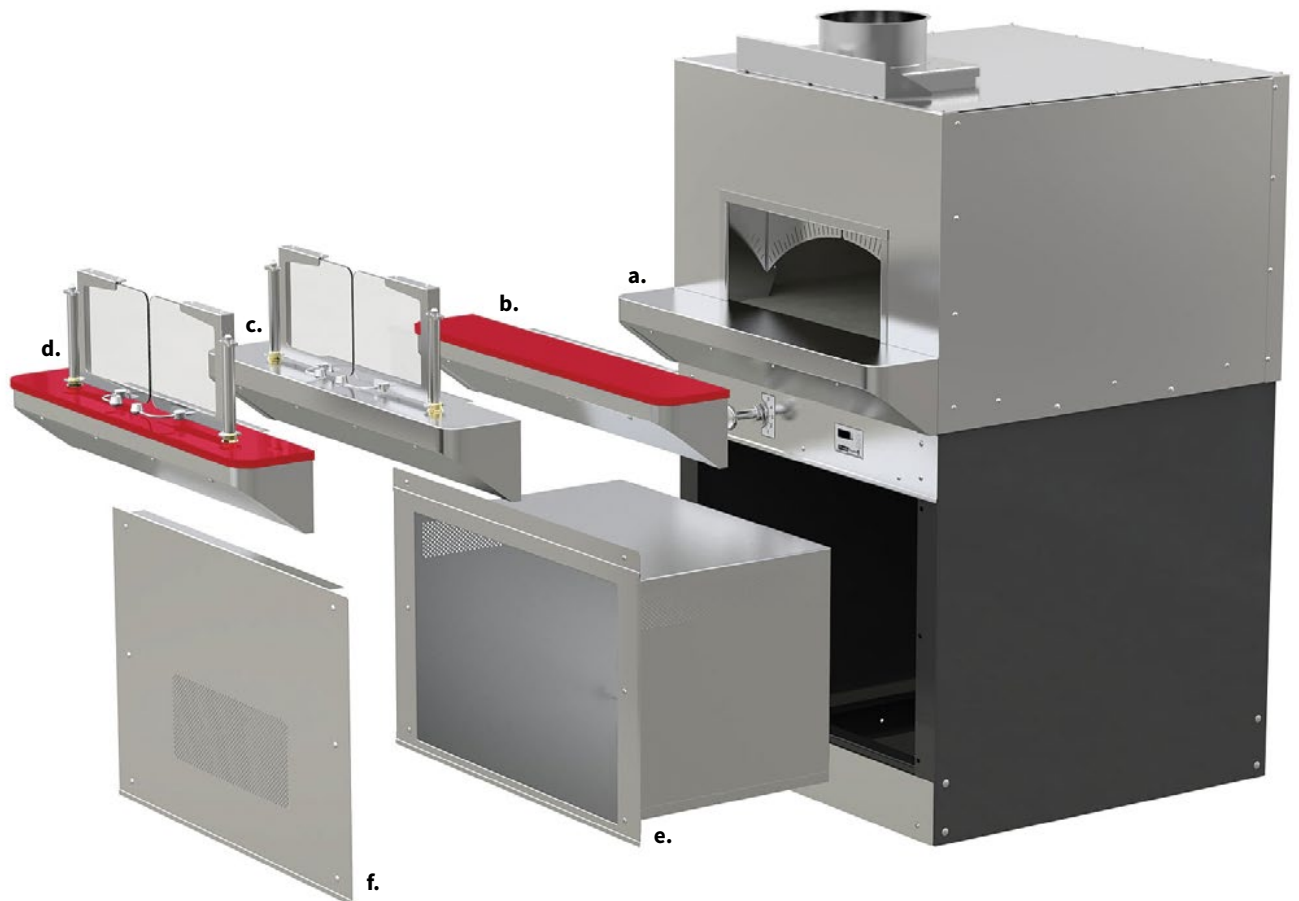



# mountain home ovens

Wood Stone Mountain Home ovens adapt beautifully to any decor, from the modern elegance of stainless steel to custom facades that can include brickwork, stonework or an amazing array of built-in options. Today's outdoor kitchens have moved beyond a barbecue grill and picnic table to become exciting entertainment areas. Indoors or outdoors, a Wood Stone Mountain Home oven can transform your kitchen while complementing the design and ambiance of your home.



# specifications

*mountain home*

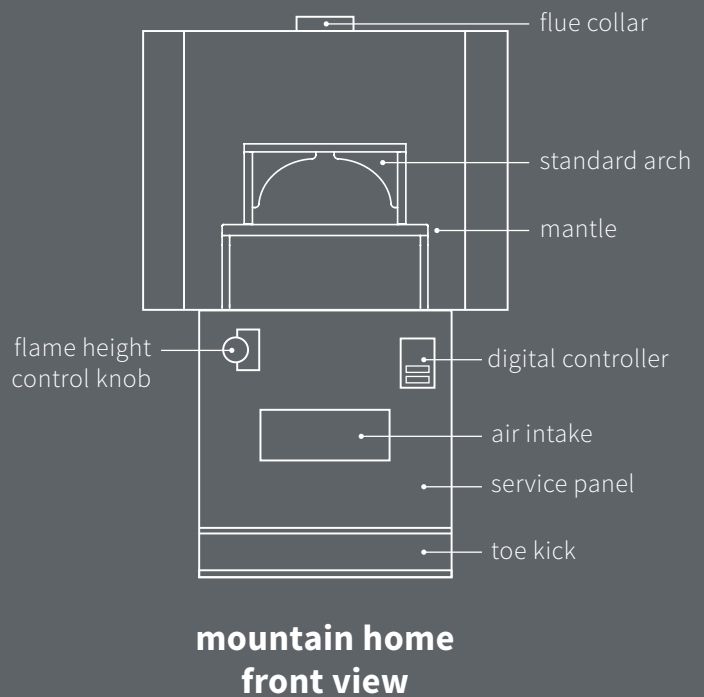
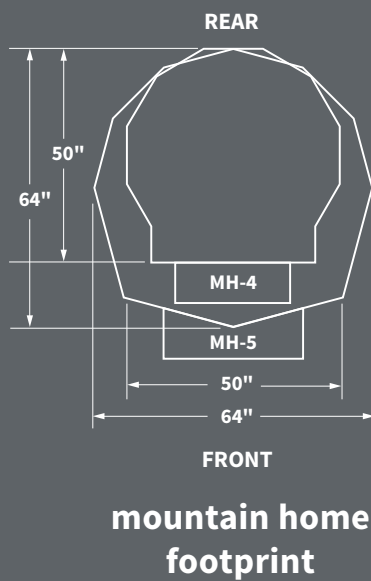



**Mt. Chuckanut 4'**

**job name:**

**model:**

	<b>WS-MH-4</b>
--	----------------

**item#:**

**fuel type:**

	<b>Gas-Fired, Wood-Fired or Combination</b>
--	---------------------------------------------

## FEATURES

- Standard door opening: 19.75 inches wide x 10 inches high
- 7 square feet of cooking surface which allows for the preparation of an array of foods - perfect for entertaining
- 4-inch thick monolithic ceramic floor and monolithic dome provide greater strength and more even heat distribution (compared to tile floors and multi-piece domes)
- Ceramic interior is heated by an adjustable radiant flame burner in the back of the oven which provides a powerful and attractive yellow flame
- Appliance body is enclosed with steel and the service panel and toe kick are made of stainless steel. The unit is supported by a black, heavy-duty steel stand
- Only 1-inch side and back clearance to combustible building materials required
- ETL Listed for residential indoor or outdoor installation
- Comes standard with stainless steel mantle and log set
- Made in the USA

## MODEL OPTIONS

### Gas-Fired:

Natural Gas: WS-MH-4-**RFG-IR-NG**

Liquid Propane: WS-MH-4-**RFG-IR-LP**

*please note: gas type (NG) or (LP) must be specified at time of order*

**Wood-Fired Only:** WS-MH-4-**W**

**Combination:** WS-MH-4-**RFG-IR-W-(NG or LP)**

## STONE HEARTH CAPACITY

**8" pizza: 12**

**10" pizza: 9**

**12" pizza: 6**

**14" pizza: 4**

## OPTIONAL ACCESSORIES

- Doorway and Service Panel Extensions
- Stainless Steel Oven Tool Set & Tool Hanger
- Black Granite Mantle
- Variable Speed Exhaust Fan
- Custom Finishes
- Wood Burning Option
- Wood Burning Accessories

### Air Quality Restrictions and Wood Burning Regulations.

Our wood-fired ovens and gas/wood combination ovens are usually classified as wood burning (solid fuel) cooking equipment and are often exempt from wood burning restrictions that pertain to wood stoves and other wood-fired heating appliances. If there are wood burning restrictions in your area, please check with the appropriate local and state air quality agencies to determine what, if any, restrictions may apply to solid fuel burning cooking equipment. For areas where wood burning is restricted, our gas-fired ovens are an exceptional alternative.

# Mt. Chuckanut 4'



## plan view

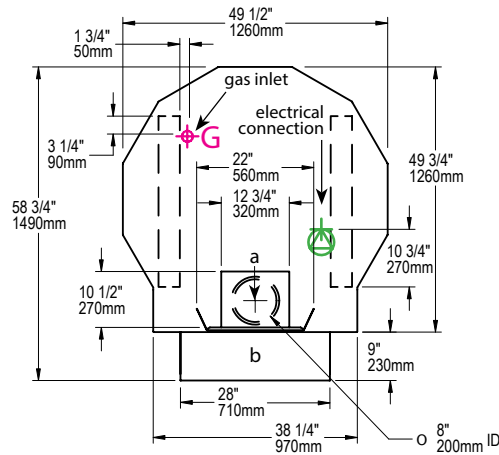

## facade information

1. All facades or enclosures are by others; all appliances require a 1-inch side clearance, and a 6-inch top clearance to combustible construction. Any construction above, and 6 inches to either side of the appliance doorway must be non-combustible. See installation manual for details.
2. Any facade or enclosure below the mantle of Gas-Fired and Combination appliances must allow the following:
  - a. Unobstructed access 16 inches to each side of centerline for removal of service/intake panel.
  - b. Easy access to all controls.
  - c. Sufficient combustion air for gas burners from the front; see installation manual for details.

a	flue collar
b	mantle
c	flame height control knob
d	digital controller
MUST BE LEFT REMOVABLE FOR SERVICE	
<p>please note: the air intake panel must be left open (do not cover/facade over) to allow for proper airflow.</p>	

## front view

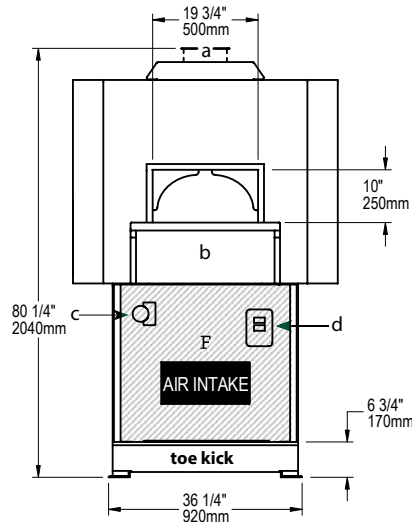

## side view

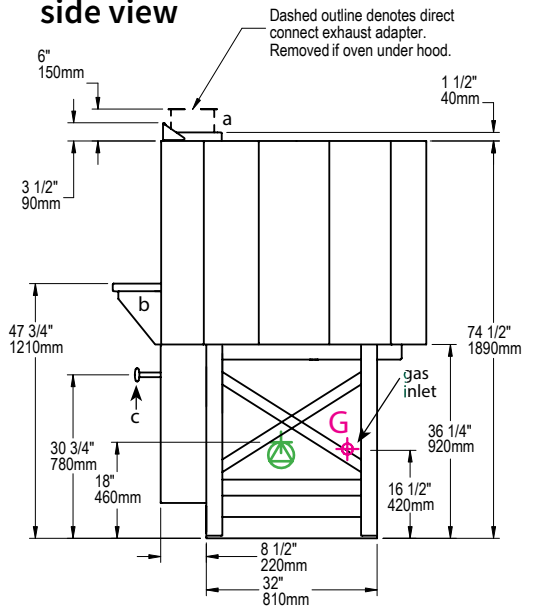

### UTILITIES

Gas: 3/4 inch gas inlet (FNPT)  
 115,000 BTU/hr Natural Gas (NG) Supply  
 OR  
 102,000 BTU/hr Propane (LP) Supply

### ELECTRICAL

120 VAC, 1.1 amp, 60 Hz  
 All utility connections made on appliance as shown  
  
 WOOD-FIRED ONLY:  
 120 VAC, 1.1 amp, 60 Hz  
 Connection made to readout box

### VENTING

This MH appliance vents through an 10-inch O.D. flue collar located above the doorway. Direct connect to a Listed building heating appliance chimney, also Listed as a grease duct, or a grease duct constructed in accordance with NFPA 96 and all relevant local and national codes, and in a manner acceptable to the authority having jurisdiction. Most installations will require an exhaust fan. See the installation manual for details.

**unit shipping weight: 2,500 lbs**



**Mt. Adams 5'**

## MODEL OPTIONS

### Gas-Fired:

Natural Gas: WS-MH-5-**RFG-IR-NG**

Liquid Propane: WS-MH-5-**RFG-IR-LP**

*please note: gas type (NG) or (LP) must be specified at time of order*

**Wood-Fired Only:** WS-MH-5-**W**

**Combination:** WS-MH-5-**RFG-IR-W-(NG or LP)**

## STONE HEARTH CAPACITY

**8" pizza: 12-16**

**10" pizza: 10-12**

**12" pizza: 8**

**14" pizza: 5**

## OPTIONAL ACCESSORIES

- Doorway and Service Panel Extensions
- Stainless Steel Oven Tool Set & Tool Hanger
- Black Granite Mantle
- Variable Speed Exhaust Fan
- Custom Finishes
- Wood Burning Option
- Wood Burning Accessories

**job name:**

**model:**

**WS-MH-5**

**item#:**

**fuel type:**

**Gas-Fired, Wood-Fired or Combination**

## FEATURES

- Standard door opening: 29.75 inches wide x 10 inches high
- 15 square feet of cooking surface which allows for the preparation of an array of foods - perfect for entertaining
- 4-inch thick monolithic ceramic floor and monolithic dome provide greater strength and more even heat distribution (compared to tile floors and multi-piece domes)
- Ceramic interior is heated by an adjustable radiant flame burner in the back of the oven which provides a powerful and attractive yellow flame
- Appliance body is enclosed with steel and the service panel and toe kick are made of stainless steel. The unit is supported by a black, heavy-duty steel stand
- Only 1-inch side and back clearance to combustible building materials required
- ETL Listed for residential indoor or outdoor installation
- Comes standard with stainless steel mantle and log set
- Made in the USA

### Air Quality Restrictions and Wood Burning Regulations.

Our wood-fired ovens and gas/wood combination ovens are usually classified as wood burning (solid fuel) cooking equipment and are often exempt from wood burning restrictions that pertain to wood stoves and other wood-fired heating appliances. If there are wood burning restrictions in your area, please check with the appropriate local and state air quality agencies to determine what, if any, restrictions may apply to solid fuel burning cooking equipment. For areas where wood burning is restricted, our gas-fired ovens are an exceptional alternative.

# Mt. Adams 5'



**plan view**

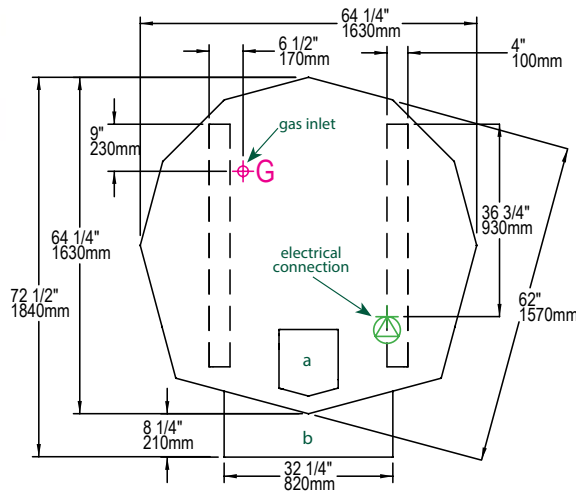

**facade information**

- All facades or enclosures are by others; all appliances require a 1-inch side clearance, and a 14-inch top clearance to combustible construction. Any construction above, and 6 inches to either side of the appliance doorway must be non-combustible. See installation manual for details.
- Any facade or enclosure below the mantle of Gas-Fired and Combination appliances must allow the following:
  - Unobstructed access 16 inches to each side of centerline for removal of service/intake panel.
  - Easy access to all controls.
  - Sufficient combustion air for gas burners from the front; see installation manual for details.

a	flue collar
b	mantle
c	flame height control knob
d	digital controller
MUST BE LEFT REMOVABLE FOR SERVICE	
<p>please note: the air intake panel must be left open (do not cover/facade over) to allow for proper airflow.</p>	

**front view**

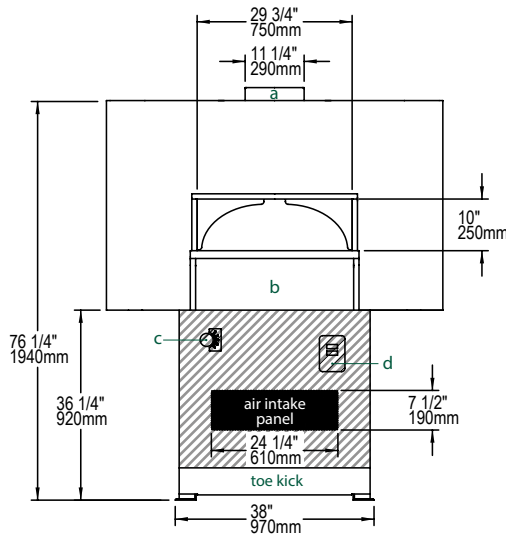

**side view**

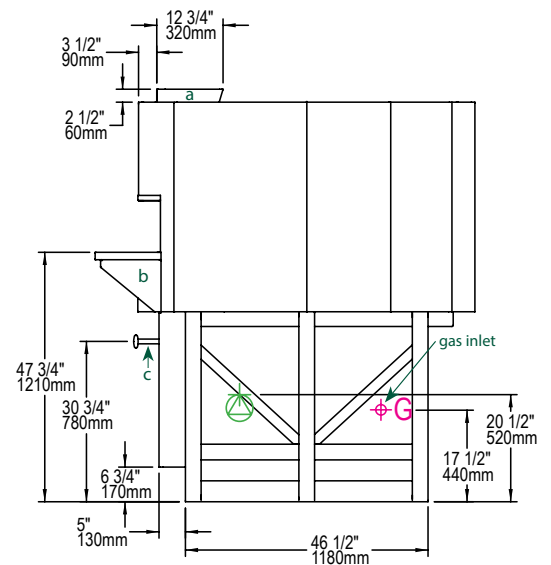

**UTILITIES** ⚡

Gas: 3/4 inch gas inlet (FNPT)  
188,000 BTU/hr Natural Gas (NG) Supply  
OR  
159,000 BTU/hr Propane (LP) Supply

**ELECTRICAL** ⚡

120 VAC, 1.1 amp, 60 Hz  
All utility connections made on appliance as shown  
  
WOOD-FIRED ONLY:  
120 VAC, 1.1 amp, 60 Hz  
Connection made to readout box

**VENTING**

This MH appliance vents through an 10-inch O.D. flue collar located above the doorway. Direct connect to a Listed building heating appliance chimney, also Listed as a grease duct, or a grease duct constructed in accordance with NFPA 96 and all relevant local and national codes, and in a manner acceptable to the authority having jurisdiction. Most installations will require an exhaust fan. See the installation manual for details.



Note: a 10-inch O.D. flue adapter is included to facilitate connection to a round duct.

**unit shipping weight: 3,600 lbs**

## FEATURES

### mountain home facade extension options

Wood Stone offers a wide range of accessories to help make your final oven installation seamless and attractive. These extensions facilitate smooth and proper connection of the oven to a facade wall. The side walls of the extensions flare out slightly to enhance user accessibility and visibility.

The extensions are constructed of stainless steel and can be ordered with or without a black granite mantle.

Extensions a, b & c work in conjunction with f, g, h & i

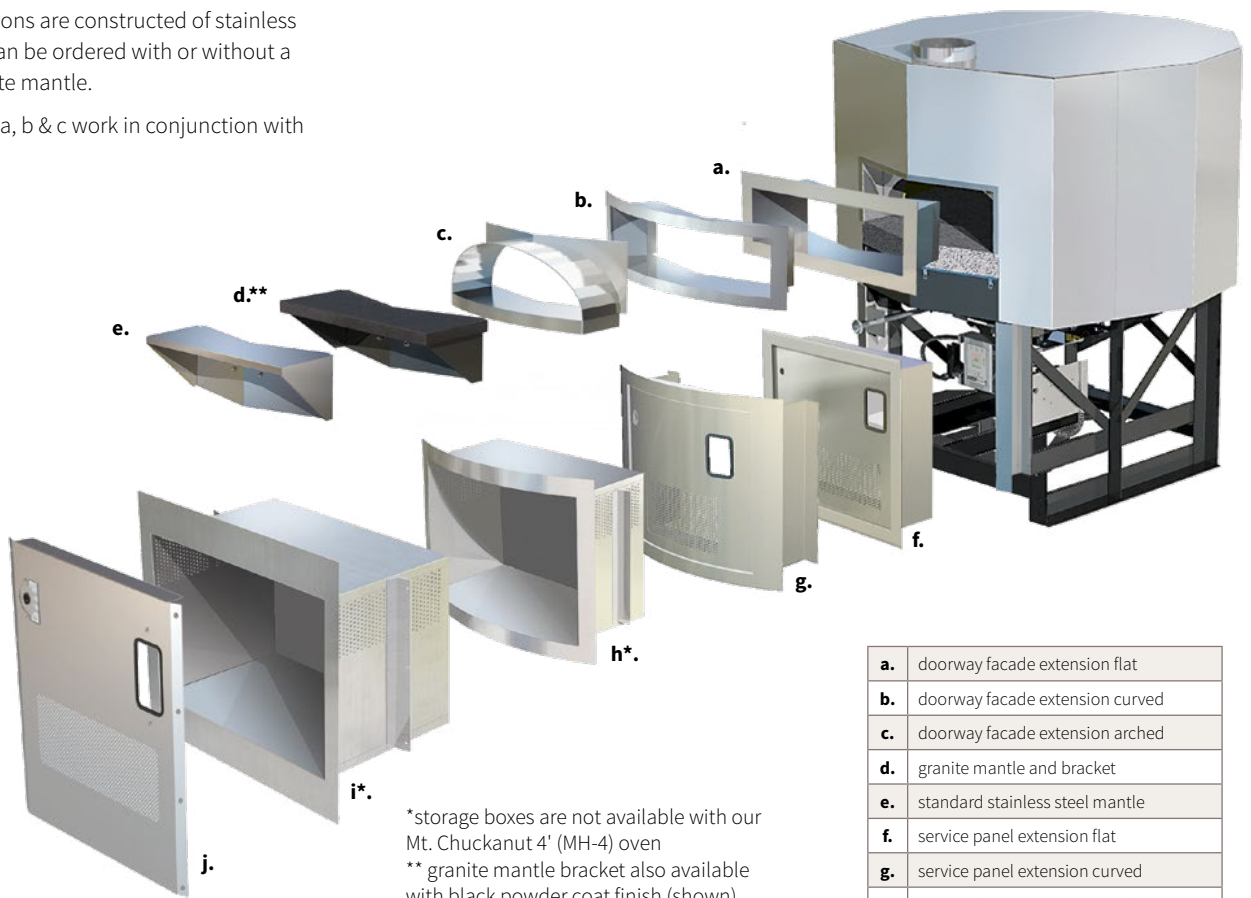

\*storage boxes are not available with our Mt. Chuckanut 4' (MH-4) oven  
 \*\* granite mantle bracket also available with black powder coat finish (shown)

job name:

model:

--	--

item#:

fuel type:

--	--

a.	doorway facade extension flat
b.	doorway facade extension curved
c.	doorway facade extension arched
d.	granite mantle and bracket
e.	standard stainless steel mantle
f.	service panel extension flat
g.	service panel extension curved
h.	storage box extension curved
i.	storage box extension flat
j.	standard stainless steel service panel

## FEATURES

### mh facade extension dimensions

NOTE: addition of granite increases dimensions F and G by 3/4 inches (below the doorway). The curved-face extensions are available in large or small radius styles.

job name:

model:

--	--

item#:

fuel type:

--	--

## plan view

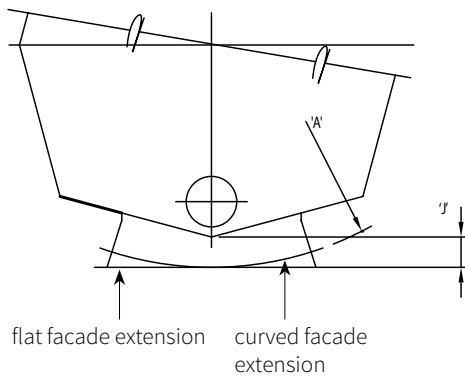

	'A'	'B'	'C'	'D'	'E'	'F'	'G'	'H'	'J'
4' CURVED	34 1/2"	29"	25"	29"	33 1/2"	10"	15"	28 1/2"	9 1/2"
4' FLAT	N/A	28 1/2"	19 1/6"	29"	34"	10"	15"	28 1/2"	6"
5' SMALL RADIUS	39"	39 1/2"	35"	30 1/2"	35"	10"	15"	28 1/2"	7"
5' LARGE RADIUS	57"	38"	33"	30 1/2"	35 1/2"	10"	15"	28 1/2"	5 1/2"
5' FLAT	N/A	40"	35"	30 1/2"	35 1/2"	10"	15"	28 1/2"	5 1/2"

## front view

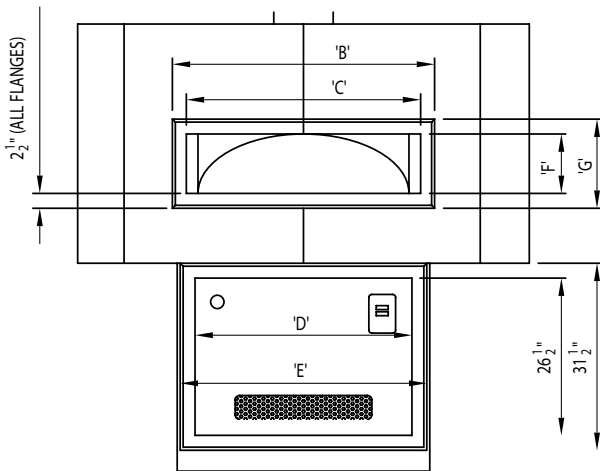

## side view

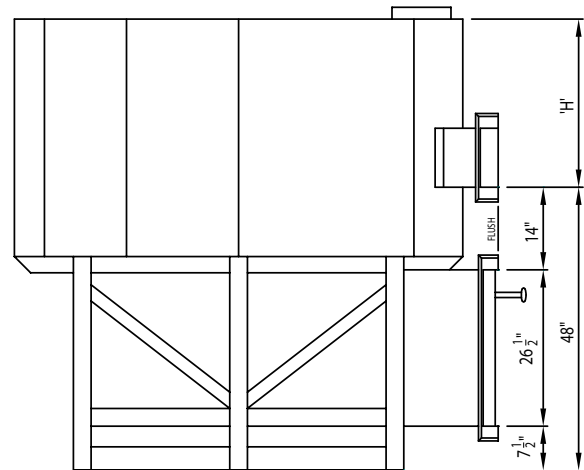

## FEATURES

### mh mantle dimensions

An oven mantle extends the working surface at the doorway of the oven, providing a staging area for dishes going into the oven or a holding area for cooked items awaiting service. Two mantle types are available through Wood Stone: stainless steel or black granite. Both mantle types come complete with all the necessary hardware for mounting.

job name:

model:

--	--

item#:

fuel type:

--	--

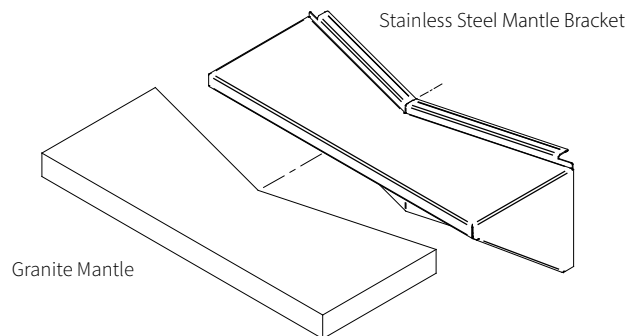
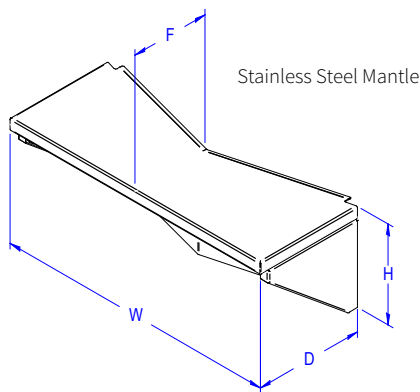
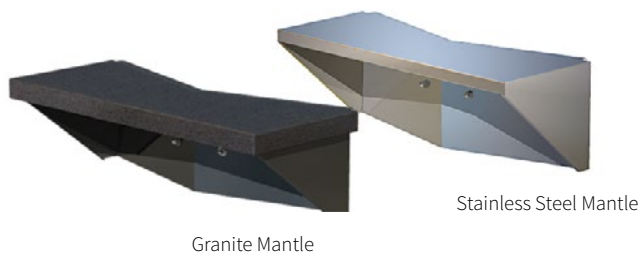

STAINLESS	H	W	F	D
Mt. Chuckanut 4'	11 ¼"	28"	9"	9"
Mt. Adams 5'	11 ¼"	32 ¼"	9 ½"	12 ½"

GRANITE	H	W	F	D
Mt. Chuckanut 4'	11 ¼"	28 ½"	10"	10"
Mt. Adams 5'	11 ¼"	34 ½"	9 ¼"	13 ¾"

## FEATURES

### a. floor brush set • WS-TL-BS

Floor brushes are vital tools for efficient oven operation. Our tool set includes several styles for complete oven cleaning: a heavy-duty, brass-bristled, wooden head beveled to facilitate debris removal from all corners of the oven, in two styles; “T-Style” (WS-TL-TFB) and the “In-Line” (WS-TL-IFB); and an in-line natural fiber brush for “sweeping” (WS-TL-NFB).

### b. bubble hook • WS-TL-BH

The bubble hook is for popping pizza dough bubbles. Made from heavy gauge stainless steel, it is also great for moving pans, trays and wood.

### c. utility peel • WS-TL-UP

Move or rotate any size pizza with nearly surgical precision with Wood Stone’s utility peel. The 8-inch diameter utility peel is also very useful for moving pans, placing wood on the fire and removing ash.

### d. particle shovel • WS-TL-PS

Our heavy gauge stainless steel shovel is designed to safely remove ash and coals from wood-fired ovens. Its front is beveled to remove ash from even hard-to-reach parts of the oven.

Note: the particle shovel is only included in the wood-fired oven tool set.

### e. large peel • WS-TL-LP-13

The head of this 13.5-inch diameter peel is made of a thinner-gauge metal than our utility peel. This peel makes it easy to transfer pizza from the prep table to the oven. It is also very handy for placing loaves of bread on the hearth.

## SETS

### f. gas-fired oven tool set • WS-TL-SET-(#)-GAS

A set of our most popular tools for use with our gas-fired ovens. Includes: (1) Large Peel , (1) Utility Peel, (1) In-Line Floor Brush, and (1) Natural Fiber Brush.

### g. wood-fired oven tool set • WS-TL-SET-(#)-W

A set of our most popular tools for use with our wood-fired ovens. Includes: (1) Large Peel , (1) Utility Peel, (1) In-Line Floor Brush, (1) Natural Fiber Brush and (1) Particle Shovel.

job name:

model:

--	--

item#:

fuel type:

--	--

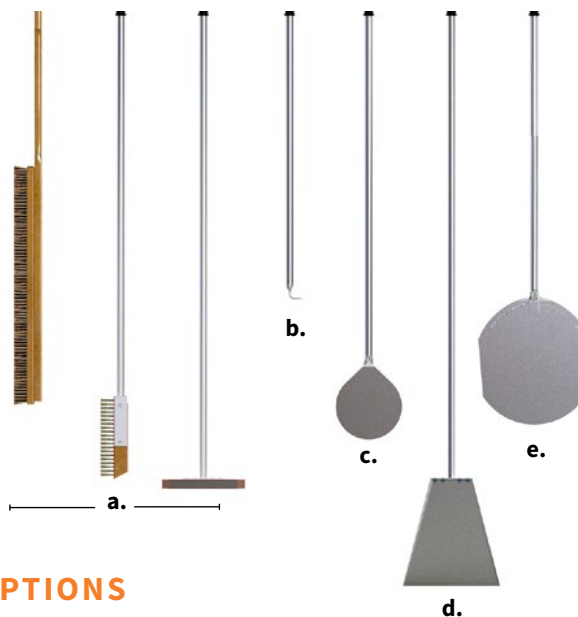

**Note:** Each tool ships with a standard tool hanger. Most Wood Stone oven tools have heavy-duty stainless handles and grease-resistant grips. NFB short & medium-sized brushes come with wooden handles.

## OPTIONS

TOOL	SHORT	MEDIUM
Large Peel (LP-13)	32"	50"
Utility Peel (UP)	40"	60"
In-Line Floor Brush (IFB)	40"	60"
T-Style Brush (TFB)	40"	60"
Natural Floor Brush (NFB)	36"	51"
Bubble Hook (BH)	40"	60"
Particle Shovel (PS)	40"	60"

What tool length does Wood Stone recommend for your oven?

<b>SHORT</b>	BH-3030, BH-4836, BH-4343, MH-4'
<b>MEDIUM</b>	BH-4355, MH-5'

## FEATURES

### tool hanger • 1650100

Wood Stone's tool hanger offers a convenient way to have your tools easily accessible while cooking. Refer to the image of the oven on the right for ideas on how this accessory can be installed onto an oven facade. Each tool purchased from Wood Stone comes with a tool hanger. The tool hanger can be purchased as a replacement accessory as well.

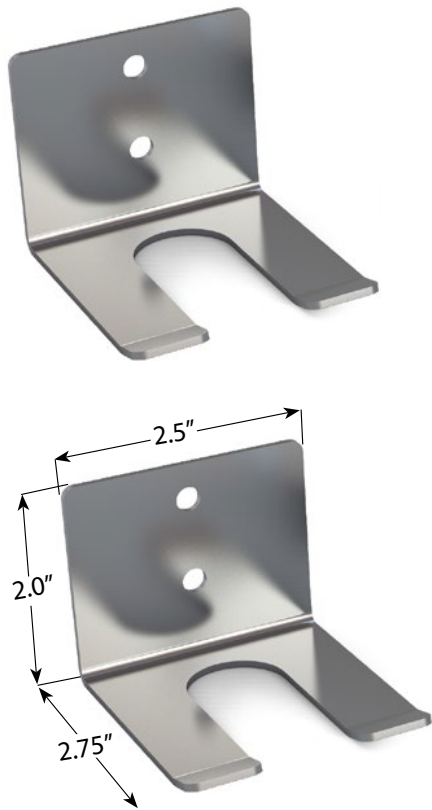

job name:

model: 1650100

--	--

item#:

fuel type:

--	--

## OPTIONS



above: oven tools and tool hangers shown installed

## FEATURES

### variable speed exhaust fan

Wood Stone is proud to carry the world's finest line of exhaust fans for stone hearth oven applications. The fans are designed to withstand the high temperatures and creosote production associated with wood burning. The construction of the fan's axial vanes creates a self-cleaning effect. Direct drive means no belts to replace. Whether venting a gas or solid fuel appliance through a hood or through a direct chimney connection, the WS-GSV is the perfect fan for the job.

Made in Denmark by Exhausto, the WS-GSV is rated for continuous operation at 450° F and comes with a flue adaptor for easy mounting on 8" or 10" duct (specify on order). No roof curb is necessary for installation of WS-GSV fans. The fan comes with a rheostat switch which allows the operator to adjust the fan speed to set the proper airflow.

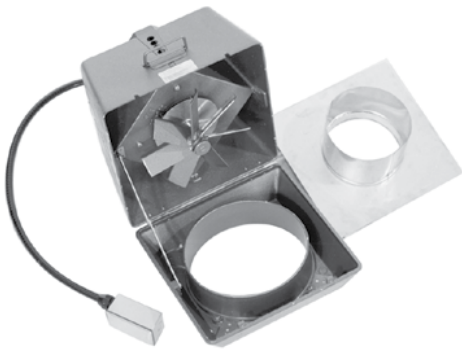

job name:

model: WS-GSV-

--	--

item#:

fuel type:

--	--

## DIMENSIONS

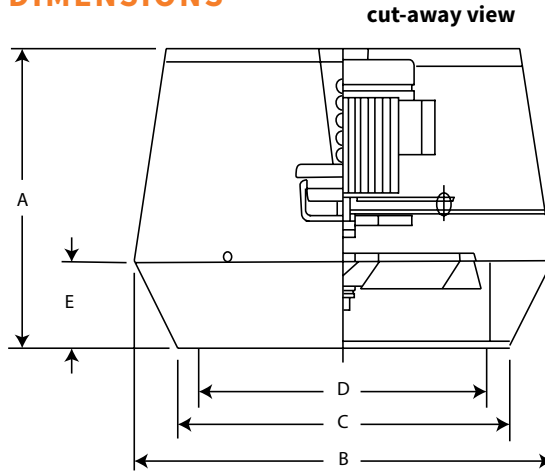

	WS-GSV-009 (inches)	WS-GSV-012 (inches)
A	9.85	11.03
B	12.21	15.37
C	9.46	12.22
D	8.63	10.72
E	2.76	3.15
lbs.	28	46
Amps	0.5	1.4
Volts	120	120

$P_s$  (in W.C.)

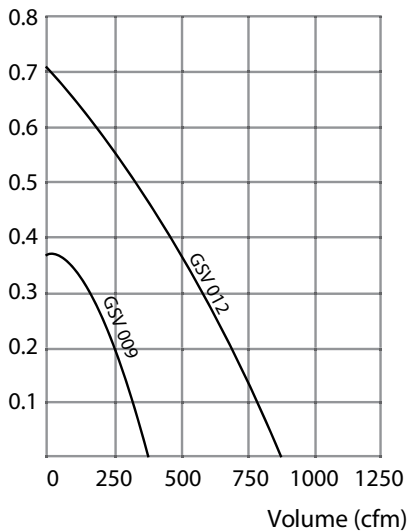

# Optional Oven Doors

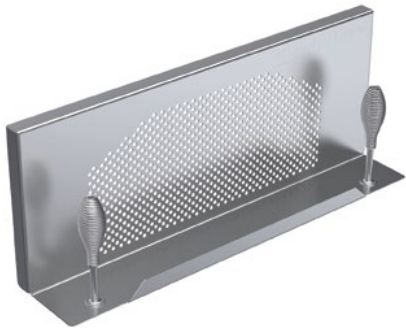

**job name:**

**model:**

--	--

**item#:**

**fuel type:**

--	--

## FEATURES

### heat-efficiency door

Wood Stone's heat-efficiency door is designed to help decrease the heat-up time required to bring your Bistro Home oven to temperature. If your oven is the centerpiece for entertaining, this stainless steel accessory can help save both time and energy!

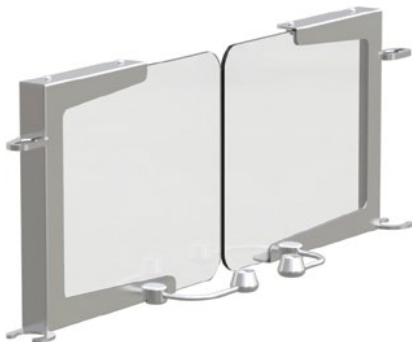

### tempered glass doors

Wood Stone's tempered glass doors are available for Bistro Home ovens. They reduce the amount of heat cast from the oven so your room stays cooler while the oven operates.



*above: both the heat-efficiency door and tempered glass doors shown*



**bistro home 4343 with stainless steel storage box**

## FEATURES

### storage boxes

Wood Stone's storage boxes are constructed of stainless steel. The storage box slides conveniently into the oven stand and is easily removable for service access. Please note this box CANNOT be used with our Mt. Chuckanut 4' (MH-4) oven.

Oven Model	Height	Width	Depth
BH-3030	22 3/8"	23 1/4"	24"
BH-4836	22 1/2"	39"	24"
BH-4343 & 4355	22 1/2"	34"	24"
MH-5	21 7/8"	29"	28"

job name:

model:

--	--

item#:

fuel type:

--	--



**BH-3030 Storage Box**  
(#0-3030-BOX-SS) - Stainless Steel



**BH-4836 Storage Box** (not shown)  
(#0-4836-BOX-SS) - Stainless Steel

**BH-4343/4355 Storage Box**  
(#0-4343-BOX-SS) - Stainless Steel



**MH-5 Storage Box**  
(#0-5-BOX-W-SS) - Stainless Steel



job name:

model:

--	--

item#:

fuel type:

--	--

## FOR WOOD-FIRED MODELS

### double compartment ash dolly • WS-TL-AD

The Wood Stone double compartment ash dolly is an efficient and safe way to store and transport the ash that needs to be removed from your oven. It has two compartment sleeves for ash storage. After the first sleeve has been filled, the second sleeve should be filled. By the time the second sleeve has been filled, the first will have had time to cool and should be safe to dump. By separating the ash into two compartments, it is easier to control the disposal of leftover ash in a safe manner.

Caution is necessary to prevent any live coals mixed in with the ash from being dumped into an area or container with combustibles. ALL ASH AND COALS SHOULD BE DOUSED WITH WATER AND EXTINGUISHED BEFORE FINAL DISPOSAL.

The unit comes with a lock eye, and a brass security lock with two keys. The unit is made of 16-gauge stainless steel with a non-marking perimeter bumper edge. It has four non-marking, fully revolving, low profile casters.

**Unit Weight: 75 lbs.**

**Minimum Shipping Weight: 140 lbs.**

plan view

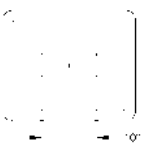

front view

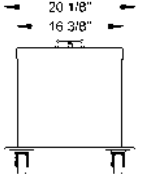

side view

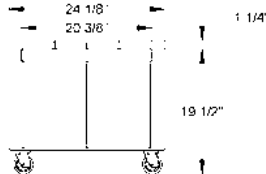

## FEATURES

### wood handling cart • WS-TL-WHC

Wood Stone's stainless steel wood handling cart is designed to address the day-to-day issues of getting fuel from the main wood storage area to your oven. The 6.5-cubic-foot capacity cart is constructed from 14-gauge stainless steel. The cart is designed to hold 18 inch logs and to contain the accompanying bark chips and sawdust. It rolls easily over thresholds and carpeting on durable, 3-inch, fully revolving, non-marking casters. This piece is built for a lifetime of reliable use.

**Unit Weight: 70 lbs.**

**Minimum Shipping Weight: 150 lbs.**

plan view



front view



side view

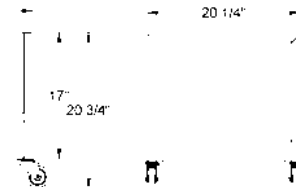

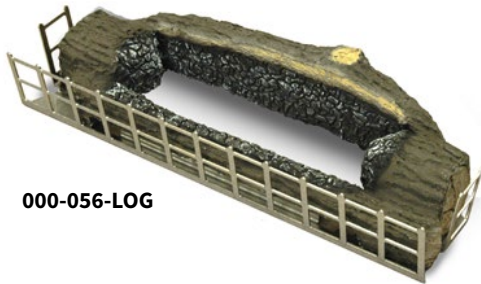

**000-056-LOG**

## FEATURES

### ceramic log sets

Wood Stone Home gas-fired ovens are designed to provide the same consistent, intense heat as our wood-fired ovens. Now the beauty of a wood-fired stone hearth oven can also be obtained without some of the challenges of using wood as a fuel source.

The ceramic log sets come with a protective stainless steel grate and fit neatly over the radiant burner. When silhouetted by the light of the oven's bright radiant flame, the illusion of a real wood fire is created.

These realistic-looking log sets come standard with every Wood Stone Home oven and can also be ordered as an accessory.

**BH 3030 • 000-3030-LOG**

**BH 4836 • 000-4343-LOG**

**BH 4343 • 000-4343-LOG**

**BH 4355 • 000-4343-LOG**

**MH 4 • 000-004-LOG**

**MH 5 • 000-056-LOG**

job name:

model:

--	--

item#:

fuel type:

--	--



**000-3030-LOG**



**000-4343-LOG**



**000-004-LOG**



Wood Stone

# professional series grill

Built from the same ceramic refractory that we use in our world-renowned stone hearth ovens, the firebox in our wood-fired professional series grill is designed to hold on to heat. This allows for greater fuel efficiency since the heated stone can replace energy that would otherwise be generated by wood or charcoal and also makes it simple to heat the entirety of the charbroiler evenly.





*Shown with stainless steel cover*

## Professional Series Grill

### MODEL OPTIONS

**Wood-Fired:**

- Countertop: WS-PWG-**5426-CT**
- With Stand & Casters: WS-PWG-**5426-00**
- With Stand & Legs: WS-PWG-**5426-01**

### OPTIONAL ACCESSORIES

- a. Broiler Shelf
- b. Stainless Steel Shelf
- c. Sauce Pan Racks
- d. Skewer (Satay) Rack



**job name:**

**model:**

**WS-PWG-5426**

**item#:**

### FEATURES

The 26" deep Professional Series Grill is an open top grill that features a "heat-sink" style firebox cast from our dense, durable high-temperature ceramic. The firebox is designed to store and radiate heat evenly. The grill is comprised of eight 6" x 16" sliding cast iron grates which rest on our unique warp-resistant, stainless steel frame system. The entire grill frame slides toward the front or back of the unit to facilitate easy fire access. A blazing fire along the rear of the firebox will produce coals, which when pulled forward, will keep the entire firebox saturated with heat. An experienced solid fuel grill operator will be impressed by the even heat delivery and fuel-saving design of the Professional Series Grill. The Professional Series Grill is available in a countertop configuration for installation on a suitable non-combustible base (by others), or on a stand equipped with heavy duty casters or legs. A Stainless Steel Rain Cover, Particle Shovel, T-Style Brass-Bristled Brush and Grate Tool are included with the grill.

#### Air Quality Restrictions and Wood Burning Regulations.

Our wood-fired appliances are usually classified as wood burning (solid fuel) cooking equipment and are often exempt from wood burning restrictions that pertain to wood stoves and other wood-fired heating appliances. If there are wood burning restrictions in your area, please check with the appropriate local and state air quality agencies to determine what, if any, restrictions may apply to solid fuel burning cooking equipment.

# Professional Series Grill



plan view

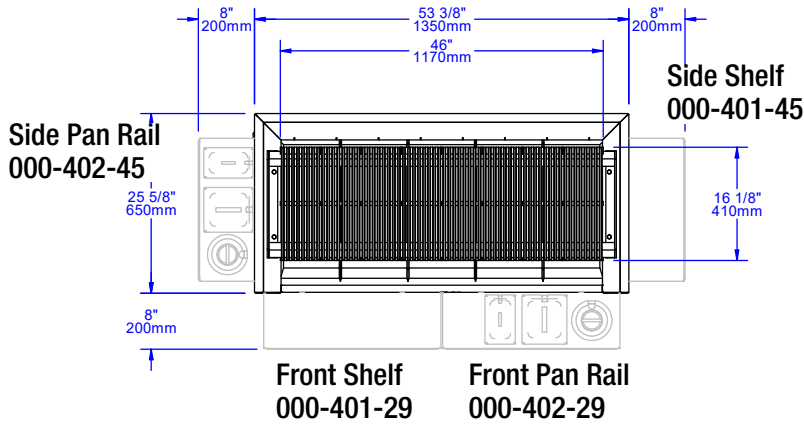

side view

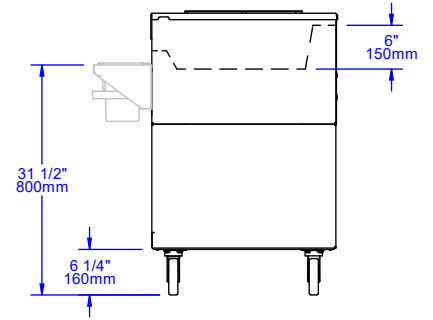

front view

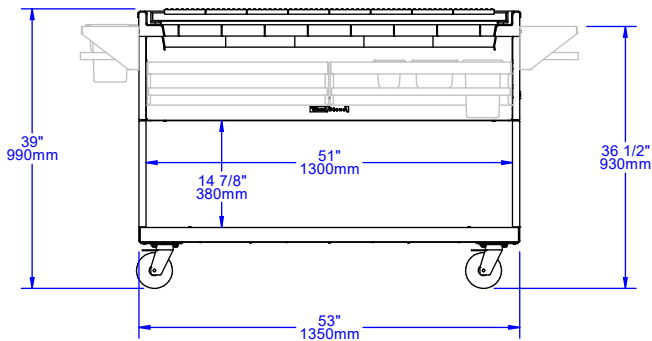

front view-CT

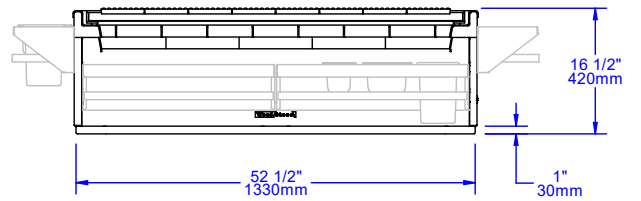

**DO NOT INSTALL THIS APPLIANCE INDOORS**

Install in accordance with all relevant local and national codes, and in a manner acceptable to the authority having jurisdiction. Installation in a covered area will require an appropriate means of venting. See the installation manual for details.

unit weight: 845 lbs





















## По вопросам продаж и поддержки обращайтесь:

Алматы (727)345-47-04  
Ангарск (3955)60-70-56  
Архангельск (8182)63-90-72  
Астрахань (8512)99-46-04  
Барнаул (3852)73-04-60  
Белгород (4722)40-23-64  
Благовещенск (4162)22-76-07  
Брянск (4832)59-03-52  
Владивосток (423)249-28-31  
Владикавказ (8672)28-90-48  
Владимир (4922)49-43-18  
Волгоград (844)278-03-48  
Вологда (8172)26-41-59  
Воронеж (473)204-51-73  
Екатеринбург (343)384-55-89

Иваново (4932)77-34-06  
Ижевск (3412)26-03-58  
Иркутск (395)279-98-46  
Казань (843)206-01-48  
Калининград (4012)72-03-81  
Калуга (4842)92-23-67  
Кемерово (3842)65-04-62  
Киров (8332)68-02-04  
Коломна (4966)23-41-49  
Кострома (4942)77-07-48  
Краснодар (861)203-40-90  
Красноярск (391)204-63-61  
Курск (4712)77-13-04  
Курган (3522)50-90-47  
Липецк (4742)52-20-81

Магнитогорск (3519)55-03-13  
Москва (495)268-04-70  
Мурманск (8152)59-64-93  
Набережные Челны (8552)20-53-41  
Нижний Новгород (831)429-08-12  
Новокузнецк (3843)20-46-81  
Ноябрьск (3496)41-32-12  
Новосибирск (383)227-86-73  
Омск (3812)21-46-40  
Орел (4862)44-53-42  
Оренбург (3532)37-68-04  
Пенза (8412)22-31-16  
Петрозаводск (8142)55-98-37  
Псков (8112)59-10-37  
Пермь (342)205-81-47

Ростов-на-Дону (863)308-18-15  
Рязань (4912)46-61-64  
Самара (846)206-03-16  
Санкт-Петербург (812)309-46-40  
Саратов (845)249-38-78  
Севастополь (8692)22-31-93  
Саранск (8342)22-96-24  
Симферополь (3652)67-13-56  
Смоленск (4812)29-41-54  
Сочи (862)225-72-31  
Ставрополь (8652)20-65-13  
Сургут (3462)77-98-35  
Сыктывкар (8212)25-95-17  
Тамбов (4752)50-40-97  
Тверь (4822)63-31-35

Тольятти (8482)63-91-07  
Томск (3822)98-41-53  
Тула (4872)33-79-87  
Тюмень (3452)66-21-18  
Ульяновск (8422)24-23-59  
Улан-Удэ (3012)59-97-51  
Уфа (347)229-48-12  
Хабаровск (4212)92-98-04  
Чебоксары (8352)28-53-07  
Челябинск (351)202-03-61  
Череповец (8202)49-02-64  
Чита (3022)38-34-83  
Якутск (4112)23-90-97  
Ярославль (4852)69-52-93

**Россия** +7(495)268-04-70

**Казахстан** +7(727)345-47-04

**Беларусь** +(375)257-127-884

**Узбекистан** +998(71)205-18-59

**Киргизия** +996(312)96-26-47

эл.почта: [wes@nt-rt.ru](mailto:wes@nt-rt.ru) || сайт: <https://wood-stone.nt-rt.ru/>